



FINGER VEIN RECOGNITION SYSTEM FOR AUTHENTICATION OF PATIENT DATA IN HOSPITAL

**BETHANNEY JANNEY.J*, SINDU DIVAKARAN
AND G.UMASHANKAR**

*Department of Biomedical Engineering, Sathyabama University,
Chennai-600119, Tamilnadu, India*

ABSTRACT

Finger vein recognition is considered as one of the most confidential biometric which is based on the images of human finger vein patterns below the skin's surface. Finger vein recognition system has several important features that set it distant from other forms of biometrics as highly protected and convenient means of personal authentication. In this paper, a finger-vein recognition system is proposed for database authentication in hospitals. The proposed system is applied on an embedded platform and executed with a novel finger-vein matching algorithm. The different components in finger vein recognition system includes: image acquisition, finger vein matching module, controller board and communication unit. The image acquisition unit was used to collect finger-vein images. The finger vein matching module directly gives the data of finger vein and will be analysed using discrete wavelet transform (DWT) in MATLAB. Matching the finger vein image with the database image is the main stage to verify the person's authentication to access the patient details. The Controller board consists of Microcontroller chip, non-invasive glucose sensor, spirometer, pulse sensor and communication port was used to execute the finger-vein matching algorithm and communicate with the peripheral device. The communication unit was used to display recognition results and the sensor values if the finger vein image is matched. Since this unit is serial communication supported it can easily incorporate into any device or micro controller. Here, the person's data will be compared with the details of the person's previous data base with the MATLAB Software program.

KEY WORDS: Biometrics, Image acquisition, Finger vein matching, Microcontroller and MATLAB.



BETHANNEY JANNEY.J*

*Department of Biomedical Engineering, Sathyabama University,
Chennai-600119, Tamilnadu, India*

*Corresponding author

Received on: 28-11-2016

Revised and Accepted on: 02-02-2017

DOI: <http://dx.doi.org/10.22376/ijpbs.2017.8.2.b5-10>

INTRODUCTION

Biometrics is the measurement and statistical analysis of an individual detail of physical, biological and behavioural characteristic. Each biometric system calculates different characteristics and then compares them with its database to check if the individual should be given access to the system or not. It is also referred to as metrics related to person characteristics.¹ Biometric systems are effective measure to protect patient confidentiality and prevent identity larceny, being used in hospitals to reorganize patient registration and identification. Nowadays hospitals are interested in implementing finger vein biometric systems as they provide a way to identify patients who arrive unconscious at the casualty ward. Biometrics authentication is used in various fields as a form of identification and access control. It is also used to identify individuals in groups that are under administration.² Finger vein authentication is claimed to be the fastest and most secure biometric method. It verifies a person's identity based on the network of minute blood vessels under the skin. Finger vein recognition is a system in which vein pattern of a finger is used for the identification of an individual. The technology of finger vein recognition is advanced as compared to the one used in finger print recognition.³ In finger vein recognition, veins are located inside the body and are extremely difficult to read or steal. Therefore there is little risk of forgery or theft. In the long term stability, a person's fingerprint may be damaged due to environment, ethnicity, or age, however skin integrity does not affect the accuracy or readability of finger vein authentication. Hence finger vein recognising system is superior than finger print. The benefit of using finger vein recognition system is that users are not required to get in the physical contact with the recognition device, which really increases its life. Instead, finger vein recognition system captures the image of finger vein pattern by transmitting near-infrared light at different angles through finger and matches it against the finger vein image stored in the database.⁴ The data of patients produced in a hospital are confidential and meant to be secure. As the numbers of patients are increasing, the data must be secured safe and confidential is an important aspect. A finger vein authentication system can become useful in this field as it can only be accessed by the authorised person.⁵ Therefore the accessing of the database becomes limited to the authorised person. The system first allows the record keeper to store his or her finger vein image, while accessing the data the finger vein image obtained by the patient is matched with the pre-stored image.

Related works

Yusuke Matsuda, *et al.*⁶ proposed and evaluated a novel method for finger-vein authentication based on feature-point matching. This method is proposed where, curvature of image-intensity profiles is used for feature point extraction because such image profiles are a robust feature against irregular shading. Moreover, a finger-shape model and non-rigid registration method are projected. Both the model and the registration method correct a deformation caused by the finger-posture change. The proposed method achieves faster

processing than SIFT. Song Dong, *et al.*⁷ presented Finger Vein Recognition Based on Multi-Orientation Weighted Symmetric Local Graph Structure which assigns weight to each edge according to the positional relationship between the edge and the target pixel. In count, they also use the Extreme Learning Machine (ELM) classifier to train and classify the vein feature extracted by the MOW-SLGS method. Experiments show that the anticipated method has better performance than traditional methods. Congcong Zhang, *et al.*⁸ described reflection-type finger vein recognition for biometric application that can be included into mobile consumer devices. In transmission-type finger-vein recognition, the camera and NIR reflection light-emitting diodes (NIR LEDs) are placed on opposite sides of the fingers. The proposed method achieved a recognition rate of 97.3% when six images are in the training set. This can be used for personal identification and it is appropriate for mobile consumer applications, which cannot be implemented by a transmission-type method. Harsha.P, *et al.*⁹ developed a real-time embedded finger-vein recognition system for authentication on teller machine. A finger-vein imaging device based on light transmission is used for more distinctive imaging. The input vein image texture features is extracted using transform-based method such as Fourier Transform and Discrete Cosine Transform. The system is suitable for application in mobile devices because of its relatively low computational complexity and low power consumption. Jose Anand, *et al.*¹⁰ designed a finger vein authentication system using template matching. Execution using Matlab shows that the finger vein authentication system performs well for user identification. The device to capture the finger vein image composed of Near Infrared (NIR) Light Emitting Diodes (LED) of 850 nanometre wavelength and a Charge Coupled Device (CCD). This method uses single sample and is convenient to the application.

MATERIALS AND METHODS

The proposed method aims to implement the secured patient database in hospitals using a finger vein authentication system. The designed system is a low cost, low power consuming device. This section includes detail description of block diagram of Hardware (Figure 2) of finger-vein recognition system. It consists of image acquisition Unit, Finger vein matching module, Controller board and communication unit.

Image Acquisition Unit

Vein patterns are invisible to the exposed eye, can be viewed through an image sensor sensitive to infrared light. For the finger vein detection camera, near infra-red LED IR333C of wavelength between 750nm to 1mm, 9v battery and 560 ohm resistor are used to illuminate the finger vein area and the image is taken with the help of a basic web camera whose IR filter has been removed.¹¹ The finger is placed over infra-red, the IR rays will penetrate the finger and the rays are captured with the help of web camera fixed in the top of the box. The web camera is positioned above the finger to

capture the finger-vein image. The image of the vein pattern is displayed in the PC.¹²

Finger Vein Matching Module

The Finger vein matching module is used in MATLAB, the MATLAB is used to process the finger vein images and perform the verification process.¹³ The Figure 1 explain the flow diagram of finger vein recognition system. The steps followed are:

(i) Preprocessing: In this stage, first take an image and is to be filtered by median filtering. After that resize the image in the standard size is 200*200. This stage is repeated for train images also.¹⁴

(ii) Feature Extraction: In this stage, filtered image is used for feature extraction process. Extract the features of an image using DWT method. DWT decompose the image into two bands: low pass filter and high pass filter. It is a lossless compression method; this method does not degrade the quality of an image¹⁵

(iii) Feature Selection: This stage selects feature of an image using Manhattan distance. This distance is used for selecting test image feature and database image feature and calculates distance between test image and database image.¹⁶

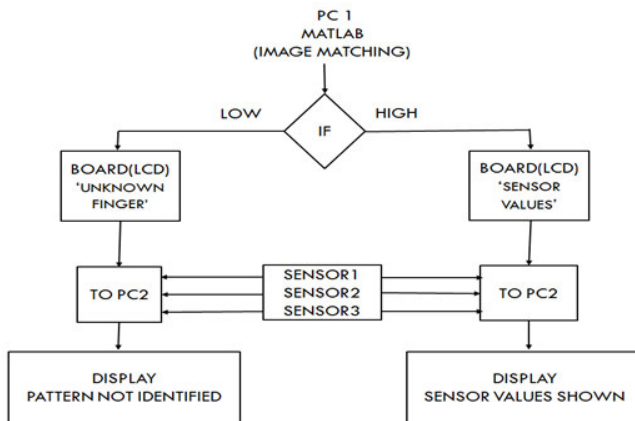

Figure 1
Flow diagram of Finger vein recognition system

Controller Board

The embedded Controller board module designed with help of AT89S52 Microcontroller and the controller is embedded with the Embedded C language. The microcontroller is the heart of the power saving unit, which get the data from PC that is Finger vein matching module, sensors and drive the control circuit. It is an integrated chip that is often part of an embedded system. The microcontroller includes a CPU RAM, ROM, I/O ports and timers like a standard computer but they are designed to execute only a single specific task to control a single system they are much smaller and

simplified so that they can include all the functions required on a single chip.¹⁷ AT89S52 Microcontroller is a low power, high-performance CMOS 8-bit microcomputer with 4K bytes of Flash programmable and erasable read only memory (PEROM). Simple Programming and removing are other features of AT89S52.¹⁸ The non-invasive glucose sensor, spirometer, pulse sensor are connected to the microcontroller. Once the values are measured from the person it is displayed in the LCD. The measured parameters are glucose level, pulse rate and oxygen level.¹⁹

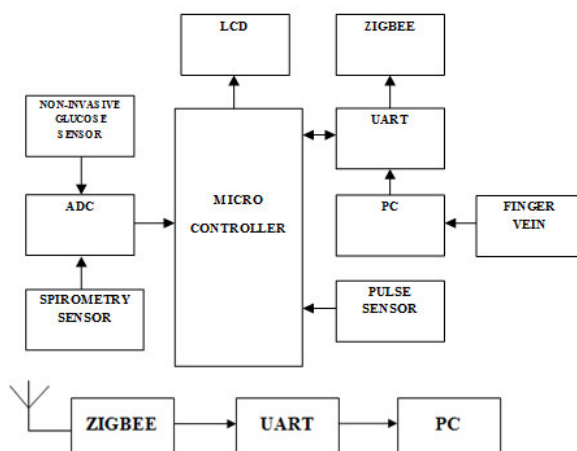

Figure 2
General block diagram of finger-vein recognition system

Communication Unit

The communication module consists of LCD display, UART and Zigbee. Fingerprint acquisition module is used to realize finger vein collecting and pre-treatment. Transmission and receiving Zigbee module is used to send the finger vein image to computer. Zigbee is a low-cost, low-power, wireless mesh network standard. The low cost allows the technology to be widely deployed in wireless control and monitoring applications. It uses the highly popular module for all its operations. It comes with a standard RS232 interface which can be used to easily interface the modem to microcontroller and for developing embedded applications. Applications like Control, data transfer, remote control and logging can be developed easily.²⁰ It can also be used in GPRS mode to connect to internet and do many applications for data logging and control. If the finger vein image is matched with the database image then the system displays the message as "matched" in the command window of MATLAB and the sensors value of heart rate, glucose level and oxygen are displayed in the LCD.²¹ If

the image is not matched, the LCD shows "UNKNOWN FINGER".

Simulation Tool

MATLAB is a programming language developed by MathWorks. MATLAB has been used in this work to process the finger vein images and perform the verification process. MATLAB tool have been used for processing all these techniques the method followed by Krasula *et al.*²² The AT89S52 microcontroller is programmed with the embedded c, through which it controls the application.

RESULTS

The designed system was tested with different finger vein images using the NIR camera. The camera gives a clear image in which the vein pattern can be easily identified. The reading was taken using the sensors and displayed on the screen. The MATLAB program correctly matches the new image and the images in the database.

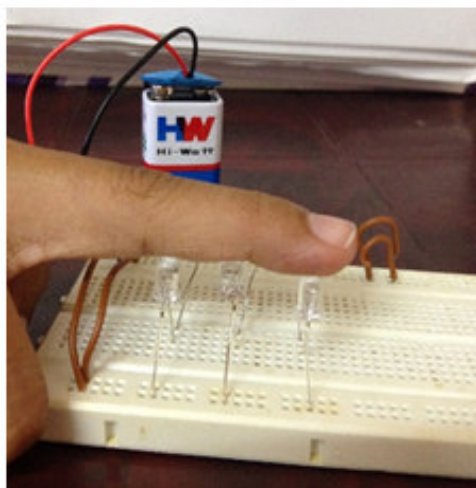

Figure 3
NIR Camera



Figure 4
Images taken using NIR camera

Figure 3 shows the NIR camera used to capture the finger-vein image. Three NIR LEDs have been used so that the entire finger is illuminated. The web camera is positioned above the finger to capture the finger-vein image. The IR filter in the web camera was removed. The images that have been captured using the camera

are shown in Figure 4. In these images the vein pattern can be identified accurately. Figure 5 shows the hardware module. It consists of an AT89S52 microcontroller, LCD, non-invasive glucose sensor, spirometer, pulse sensor and a transformer.

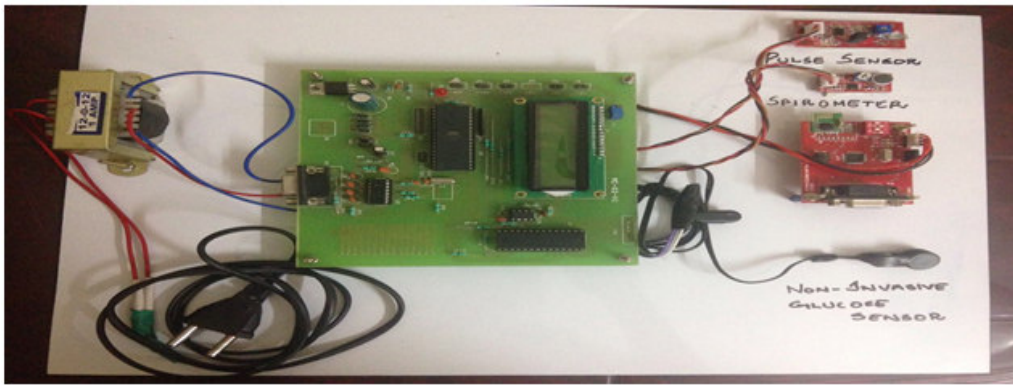
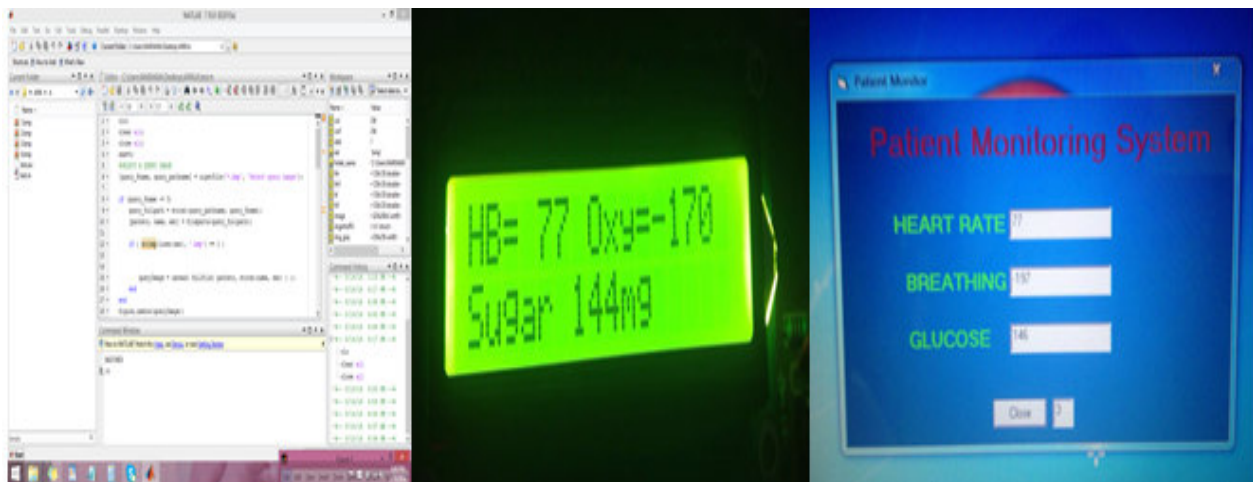

Figure 5
Design of Hardware



(a) MATLAB Output

(b) LCD Output

(c) Visual Basics Output

Figure 6
Showing the output for Finger vein matched

If the finger vein image is matched perfectly with the database image a MATCHED message is displayed in the command window as shown in the Figure 6 (a). If the images are a match then an output 'A' is sent to the

hardware module, this output allows the LCD to show the sensor values as shown in Figure 6 (b). Finally the sensor values are shown in the second PC, Figure 6 (c).

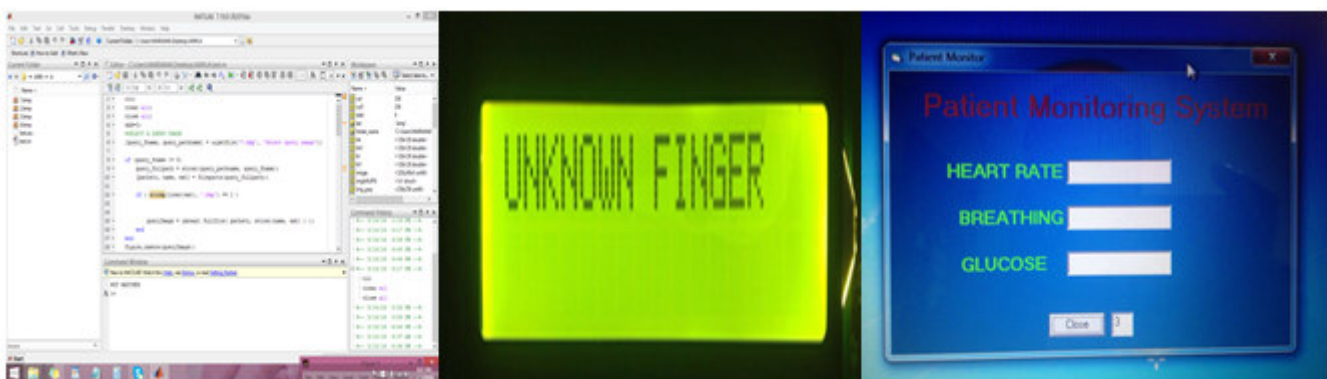

(a)MATLAB Output

(b) LCD Output

(c) Visual Basics Output

Figure 7
Showing the output for Finger vein not matched

When the given image is not present in the database 'NOT MATCHED' output is shown in the MATLAB software as shown in Figure 7 (a). Hence an output signal 'B' is passed to the hardware module. This makes the LCD to show 'UNKNOWN FINGER' as shown in

Figure 7(b). Therefore no values are shown in the second PC, Figure 7(c).

CONCLUSION

In hospitals patient data security is very important. This paper has been implemented for improving the patient data security and authentication based on biometric system. Finger vein recognition uses biometric authentication techniques based on the images of the human finger vein pattern. This system has been implemented on an embedded platform and equipped with a finger vein recognition algorithm. In this work, the patient's data will be compared with the details of the earlier data of that same patient. The measured glucose value, pulse rate and oxygen level of the human are displayed in the LCD and the values are transmitted to the hospital PC and it is hidden. Once the finger vein authentication is completed then the hidden medical records of the particular person can be seen.

REFERENCES

1. Sujata Kulkarni, Rautb RD and Dakholec PK. A Novel Authentication System Based on Hidden Biometric Trait. International Conference on Computational Modelling and Security (CMS 2016). Elsevier,Procedia Comput Sci 2016; 85: 255-62.
2. Sun X, Lin C, Li M, and Chen Q. A DSP-based finger vein authentication system. Proceedings of the Fourth International Conference on Intelligent Computation Technology and Automation. 2011: 333-6.
3. Wu JD and Liu CT. Finger-vein pattern identification using SVM and neural network technique.Expert Syst Appl. 2011; 38(11): 14284–9.
4. Sujata Kulkarni, Raut R D. Finger Vein Recognition. International Conference on Advances in Engineering & Technology. J Electr Electron Eng Journal of Electrical and Electronics Engineering. 2014: 32-6.
5. Ajay Kumar and Yingbo Zhou. Human Identification Using Finger Vein.IEEE Trans Image Process. 2012; 21(4): 2228-44.
6. Yusuke Matsuda, Naoto Miura, Akio Nagasaka, Harumi Kiyomizu, Takafumi Miyatake. Finger-vein authentication based on deformation-tolerant feature-point matching, Mach Vis Appl . 2016; 27: 237–50.
7. Song Dong, Jucheng Yang, Yarui Chen, Chao Wang, Xiaoyuan Zhang and Dong Sun Park. Finger Vein Recognition Based on Multi-Orientation Weighted Symmetric Local Graph Structure.KSII Trans Internet Inf Syst . 2015; 9(10): 4126-42.
8. Congcong Zhang, Zhi Liu, Yi Liu, Fangqi Su, Jun Chang, Yiran Zhou, and Qijun Zhao. Reflection-type Finger Vein Recognition for Mobile Applications. J Opt Soc Korea . 2015; 19(5): 467-76.
9. Harsha.P, Kanimozhi R, Subashini C. A Real Time Embedded System of Vein used for Authentication in Teller Machine. Int J Emerg Tehnol Adv Eng . 2013; 3: 400-5.
10. Jose Anand, Arul Flora TG, Anu Susan Philip. Finger-Vein Based Biometric Security System. Int J Res Eng Technol . 2010; 2(12): 197-200.
11. Yuan Weiqi, Yang Guotian, Li Wei. Research on palm vein acquisition system based on wavelength choice. J. Laser & Infrared.2011; 41(2): 234-9.
12. Li Wei, Yuan Weiqi. Imaging quality analysis on palm vein under different Wavelengths near-IR. Comput Eng Appl . 2011; 47(30): 15-8.
13. Dipti Verma, Sipi Dubey. Processing and Enhancement of Palm Vein Image in Vein Pattern Recognition System. Int J Comput Sci Mob Comput . 2015; 4(4): 137-41.
14. Ishani Sarkar, Farkhod Alisherov, Tai-hoon Kim, and Debnath Bhattacharyya. Palm Vein Authentication System: A Review. Int J Control Autom . 2010; 3(1): 27-34.
15. Deepamalar M. and Madheswaran M. An Enhanced Palm Vein Recognition System Using Multi-level Fusion of Multimodal Features and Adaptive Resonance Theory. Int J Comput Appl . 2010; 1(20): 95-101.
16. Yu Lu, Sook Yoon, Xie SJ, Wang ZH, and Dong SP. Finger Vein Recognition Using Generalized Local Line Binary Pattern.KSII Trans Internet Inf Syst . 2014; 8(5):1766–84.
17. Zhi Liu and Shangling Song. An Embedded Real-Time Finger-Vein Recognition System for Mobile Devices. IEEE Trans consumer electronics . 2012; 58(2): 552 – 7.
18. Nandhini P, Hari Krishnan G and Umashankar G. Home Based Telemedicine System for Respiratory Disorder Patients. Int J Pharma Bio Sci . 2015; 6(4): 227 - 31.
19. Nandhini P, Bethanney Janney J and Sindu Divakaran, Design of an Intelligent Pillow with Maternal Temperature and Heartbeat Vibrations for Comforting NICU Infants.Indian J Sci Technol . 2016; 9(33):1-5.
20. Bethanney Janney J, Krishnakumar S, Jangam Valet Dinakar and Dilip Kumar Reddy S. Detection and Monitoring of Victims Trapped under Collapsed Buildings using Wireless Communication.Int J Pharm Technol. 2016; 8(1):11056-64.
21. Wang D, Li J, and Memik G. User identification based on finger vein patterns for consumer electronics device. IEEE Trans consumer electronics . 2010; 56(2): 799-804.
22. Krasula L, Kklima M, Rogard E, and Jeanblanc E. Radioengineering. 2011; 20(4).

Experiment results show that it consumes low power and has less computational complexity. Further works include searching fast computation transform algorithm and designing better image capture system.

ACKNOWLEDGEMENT

The authors would like to thank Sathyabama University, School of Bio and Chemical Engineering, Department of Biomedical Engineering for providing facilities for carrying on and executing the research work.

CONFLICT OF INTEREST

Conflict of interest declared none.

Reviewers of this article

Dr. S. Krishnakumar M.Sc., Ph.D.,

Associate Professor, Department of
Biomedical Engineering, Sathyabama
University
Chennai, India



Prof. Y. Prapurna Chandra Rao

Assistant Professor, KLE University,
Belgaum, Karnataka



Prof. Dr. K. Suri Prabha

Asst. Editor, International Journal
of Pharma and Bio sciences.



Prof. P. Muthu Prasanna

Managing Editor, International
Journal of Pharma and Bio sciences.

We sincerely thank the above reviewers for peer reviewing the manuscript